

Certificate model name: MIRA 22 T2

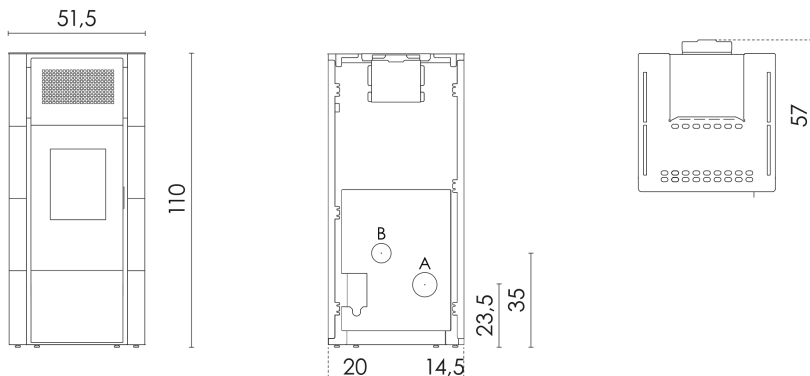

Hydro pellet stoves

TECHNICAL DATA

Thermic Power (at min-at max)	kW	4,9 - 22,4
Introduced thermal power (at max)	kW	24,3
Water useful power (at min-at max)	kW	18,0 - 3,4
Seasonal energy efficiency	ηs [%]	89
Useful efficiency (at min-at max)	%	96 - 92
Heatable volume (at min-at max)	m ³	137 - 538
CO ₂ (min-max)	%	7,9- 13,6
Emissions CO (13% O ₂) (at min-at max)	mg/Nm ³	150 - 136
Emissions OGC (13%O ₂) (at min-at max)	mg/Nm ³	3,0- 2,0
Emissions NOX (13% O ₂) (at min-at max)	mg/Nm ³	94 - 99
Dust content at 13% O ₂ (at min-at max)	mg/Nm ³	18 - 14
Fuel Pellet	mm	Ø6 L=3÷40
Boiler capacity (H ₂ O)	l	14
Hopper capacity	kg	22
Hourly consumption (at min-at max)	kg/h	1,0 - 5,1
Autonomy (at min-at max)	h	22 - 4
Supply and frequency	V-Hz	230-50
Ignition electrical absorption	W	343
Operating electrical absorption (at max)	W	117
Chimney flue depression (at min-at max)	Pa	2 - 10
Mass of smoke (at min-at max)	g/sec	4,5 - 12,1
Exhaust fumes temperature (at min-at max)	°C	66 - 183
Distance from material comb. (back/side/under)	mm	200 / 200 / 12
Distance to material comb. (front/top)	mm	2000 / 750
Exhaust fumes outlet (A)	Ø mm	80
Combustion air inlet (B)	Ø mm	60
Appliance Type (tightness)	Type	BF

PLUS

Back exhaust	Airtight pellet stove	Cast iron burning pot
Daily weekly programming	Air temperature sensor	Wi-Fi (optional)
Silent	Water temperature sensor	Easy Start brazier

AVAILABLE FINISHES

7022280		Steel White	EAN 8053859018278
7022281		Steel Red Bordeaux	EAN 8053859018285
7022282		Steel Anthracite	EAN 8053859018292

CERTIFICATIONS

European standards
BlmSchV 2015
Regensburg
München
Stuttgart
Aachen



EN 16510-1:2022 / EN 16510-2-6:2022



STOVE PACKAGE

	L (cm)	H (cm)	P (cm)
	80	132	71
	Volume (m ³)	0,75	
	Gross weight (kg)	153,6	
	Net weight (kg)	140	

STORAGE

	N° (max)
	1

TRANSPORT

57 pz